

Solitherm

Technische Daten Technical Data Données techniques Dati tecnici



Bratta by Fusch

Prüfungen Tests Tests Verifiche

DIN EN 13240 :2001 + A2:2007 15a B-VG (A) :FK 40 12 125 VKF-Nr.:23598 (CH)

BStV München, Regensburg und Stuttgart FBStVO Aachen

1. und 2. Stufe der 1.BImSchV Deutschlands, sowie die Luftreinhalteverordnung der Schweiz

Allgemeine bauaufsichtliche Zulassung (DIBt) Z-43.12-306

Feuerungswerte¹ Valeurs de combustion¹ Combustion values¹ Valori di combustione¹

	Holz ²	
Nennwärmeleistung (NWL) <input type="checkbox"/> Puissance calorifique nominale <input type="checkbox"/> Nominal thermal output <input type="checkbox"/> Potenza termica nominale	6	kW
Wärmeleistungsbereich <input type="checkbox"/> Plage de puissance calorifique <input type="checkbox"/> Output range <input type="checkbox"/> Range di potenza calorifica	4 - 7	
Abgasmassenstrom <input type="checkbox"/> Flux massique des gaz brûlés <input type="checkbox"/> Flue gas mass flow rate <input type="checkbox"/> Flusso volumetrico dei fumi	5,88	g/s
Abgasstutentemperatur <input type="checkbox"/> Température à la sortie des gaz brûlés <input type="checkbox"/> Flue gas outlet temp <input type="checkbox"/> Temperatura del condotto di scarico fumi	329	°C
Mindestförderdruck bei NWL <input type="checkbox"/> Pression minimum de refoulement à la puissance nominale <input type="checkbox"/> Min. supply pressure at nominal thermal output <input type="checkbox"/> Pressione minima di mandata a potenza nominale	12	Pa
Wirkungsgrad <input type="checkbox"/> Rendement <input type="checkbox"/> Efficiency <input type="checkbox"/> Rendimento	79,94	%
Feinstaub <input type="checkbox"/> Poussières <input type="checkbox"/> Particulate matter <input type="checkbox"/> Polveri fini	30	mg/Nm ³
CO-Gehalt <input type="checkbox"/> Teneur en CO <input type="checkbox"/> CO content <input type="checkbox"/> Contenuto CO	750	mg/Nm ³
Mittlerer CO₂-Gehalt <input type="checkbox"/> Contenu moyen en CO ₂ <input type="checkbox"/> Average CO ₂ content <input type="checkbox"/> Contenuto medio di CO ₂	8,71	%
C_nH_m	62	mg/Nm ³
NO_x	115	mg/Nm ³
Raumheizvermögen (abhängig von der Isolierung des Hauses in m²) <input type="checkbox"/> Volume de chauffe en m ² en fonction de l'isolation, du bâtiment <input type="checkbox"/> Room heating capacity (depending on the insulation of the house in m ²) <input type="checkbox"/> Potere di riscaldamento dell'ambiente (in funzione dell'isolamento, dell'abitazione in m ²)	40 - 70	m ²

¹Bei 13% O₂ Pour 13% de O₂ At 13% O₂ Con 13% O₂

²Bois Wood Legna.

Maße & Gewicht Dimensions & poids Dimensions & weights Dimensioni & peso

Maße in cm Dimension en cm Dimensions in cm Dimensioni in cm

a Höhe <input type="checkbox"/> Hauteur <input type="checkbox"/> Height <input type="checkbox"/> Altezza	164,5
b Breite <input type="checkbox"/> Largeur <input type="checkbox"/> Width <input type="checkbox"/> Larghezza	47,2
c Tiefe <input type="checkbox"/> Profondeur <input type="checkbox"/> Depth <input type="checkbox"/> Profondità	47,2
d Anschlusshöhe hinten <input type="checkbox"/> Hauteur de raccordement à l'arrière <input type="checkbox"/> Connection height for rear installation <input type="checkbox"/> Altezza di collegamento posteriore	146,4 - 148,5
e Distanz Ofenrückwand / Rauchrohrmitte <input type="checkbox"/> Distances arrière du poêle / centre conduit de fumée <input type="checkbox"/> Distance from rear stove wall / flue pipe centre <input type="checkbox"/> Distanza parete posterior della stufa / centro della canna fumaria	23,6
f Verbrennungsluftstutzen Anschlusshöhe hinten Mitte Stutzen <input type="checkbox"/> Embout à air de combustion <input type="checkbox"/> Hauteur de raccordement au milieu du conduit arrière <input type="checkbox"/> Combustion air inlet port height, rear center piece <input type="checkbox"/> Bocchettone per l'aria di combustione Altezza di collegamento posterior al centro del bocchettone	17,2 - 19,2
g Distanz Ofenrückwand / Verbrennungsluftstutzenmitte unten <input type="checkbox"/> Distances arrière du poêle / centre embout à air de combustion bas <input type="checkbox"/> Distance rear wall / combustion air nozzle bottom center <input type="checkbox"/> Distanza parete posterior della stufa / centro del bocchettone per l'aria di combustione inférieure	23,6
Rauchgasstutzen hinten / oben <input type="checkbox"/> Raccordement de fumées en arrière / au dessus <input type="checkbox"/> Flue outlet rear / top <input type="checkbox"/> Scarico fumi posteriore / superiore	Ø 15
Externe Luftzufuhr hinten / unten <input type="checkbox"/> Arrivée d'air externe arrière / bas <input type="checkbox"/> External air supply at rear / below <input type="checkbox"/> Alimentazione dell'aria esterna posteriore / inferiore	Ø 10
Feuerraum (H x B x T) <input type="checkbox"/> Foyer (H x L x P) <input type="checkbox"/> Fire box (H x W x D) <input type="checkbox"/> Focolare (A x L x P)	54 x 28 x 36,5 (28 x 26)
(Feuermulde (B x T)) <input type="checkbox"/> Cuvette foyer (L x P) <input type="checkbox"/> Fire trough (W x D) <input type="checkbox"/> Cavità carbonella (L x P)	
Gewicht in kg <input type="checkbox"/> poids en kg <input type="checkbox"/> weights in kg <input type="checkbox"/> pesi in kg	290

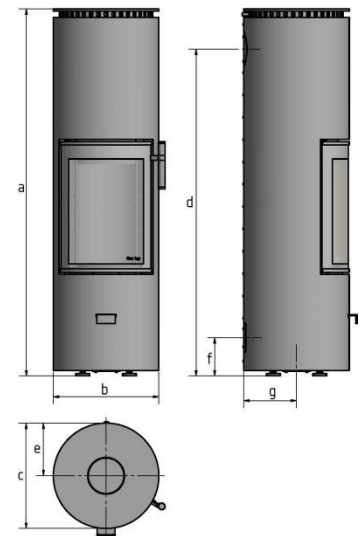

Sicherheitsabstände Distances de sécurité Safety Distances Distanze di sicurezza

Maße in cm Dimensions en cm Dimensions in cm Dimensioni in cm

Abstände zu brennbaren Materialien

Distances aux matériaux combustibles
Distances to combustible materials
Distanze da materiali combustibili

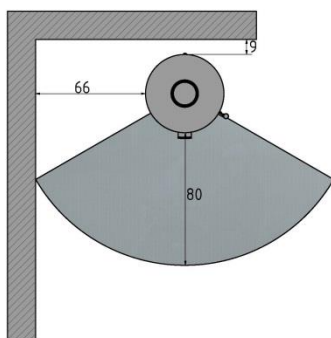

Größe der Bodenplatte

Taille de la plaque de sol
Size of floorplate
Dimensione della piastra di base

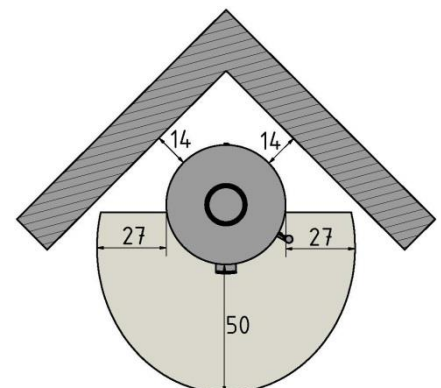
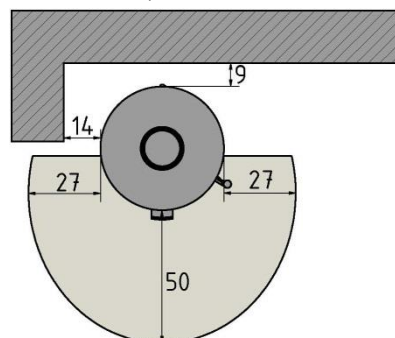

Bitte beachten Sie zusätzlich die Informationen und Hinweise in der Bedienungsanleitung!

Par ailleurs, veuillez respecter les informations et indications du mode d'emploi!
Please also observe the information and notes in the operating instructions!

Attenersi ulteriormente alle informazioni e alle indicazioni presenti nelle istruzioni per l'uso!

Technische Änderungen vorbehalten ∪ Sous réserve de modifications techniques ∪ Subject to technical modifications ∪ Con riserva di modifiche tecniche ∪